

1. Contents of the Package

The types of parts included in the package varies depending on the Model (Model and Suffix Code). Check that the following parts are included. If the contents are not correct or missing or if there is physical damage, contact the dealer from which you purchased them.

Model 707863-E6 (Complies with ANSI/EIA Standard)

Parts Name	Quantity	Notes	Parts Name	Quantity	Notes
Rack frame	1		M5 Binding-head screws	6	Length: 12 mm
M3 Binding-head screws	2	Length: 8 mm	Cover sticker	4	

Model 707863-J6 (Complies with JIS Standard)

Parts Name	Quantity	Notes	Parts Name	Quantity	Notes
Rack frame	1		Upper bracket	1	
M5 Binding-head screws	6	Length: 12 mm	M3 Binding-head screws	4	Length: 8 mm
Cover sticker	4				

2. Procedure for Removing the Parts from the Station for Rack Mounting

Removing the handle

Note

You may not be able to reattach the handle once you remove it.

1. Insert a Philip's head screw driver in the direction of arrow A, and remove the cover by lifting the handle cover (a). Remove all four covers. If it does not come off easily, use another tool to widen the right and left sides of the handle cover while lifting it up.
2. Remove the two attachment screws (b) that are holding down each handle.

Removing the bottom feet and the station cover attachment screws

Note

You will not be able to reattach the screws (d) of the bottom feet (c) once you remove them. The bottom feet (Model: B9951CP, four pieces needed for the station) are available as optional accessories (sold separately). For information and ordering, contact the dealer from which you purchased the measuring station.

1. Loosen the screws (d) embedded in the feet (c) until the feet come off (four locations).
2. Remove the attachment screws (e) on the bottom side that are holding the station cover (two locations).

Removing the sealing labels

Peel off the sealing labels (f) (six locations).

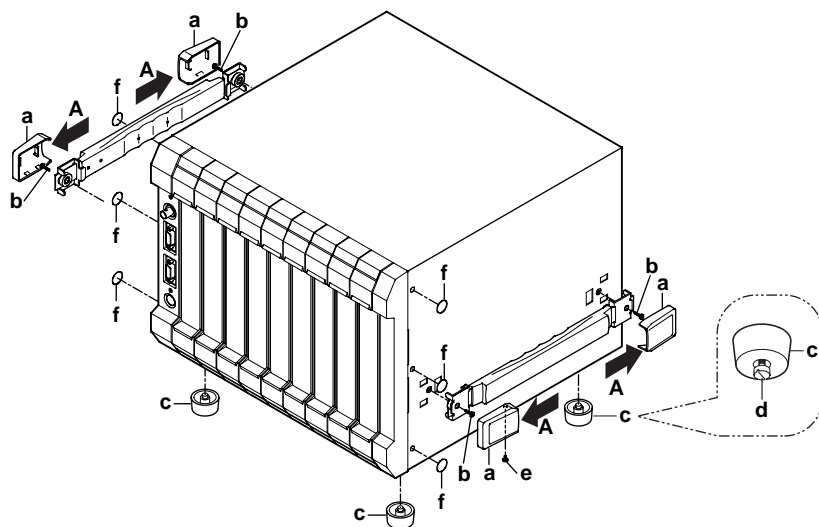

3. Procedure for attaching the rack mount fitting

1. Stick sealing labels (1) on the holes where the handle was attached (four locations).
2. Attach the left side of the station to the left side of the rack frame (2) using M5 binding-head screws (3) (three locations).
Tightening torque reference: 2.8 to 2.9 N·m
3. Attach the right side of the station to the right side of the rack frame (2) using M5 binding-head screws (3) (three locations).
Tightening torque reference: 2.8 to 2.9 N·m
4. Attach the bottom side of the station to the bottom of the rack frame (2) using M3 binding-head screws (4) (two locations).
Tightening torque reference: 0.6 to 0.7 N·m
5. For Model 707863-J6 (JIS Standard) only, attach the upper bracket (5) to the rack frame (2) using M3 binding-head screws (two locations).
Tightening torque reference: 0.6 to 0.7 N·m

Model 707863-E6 (ANSI/EIA Standard)

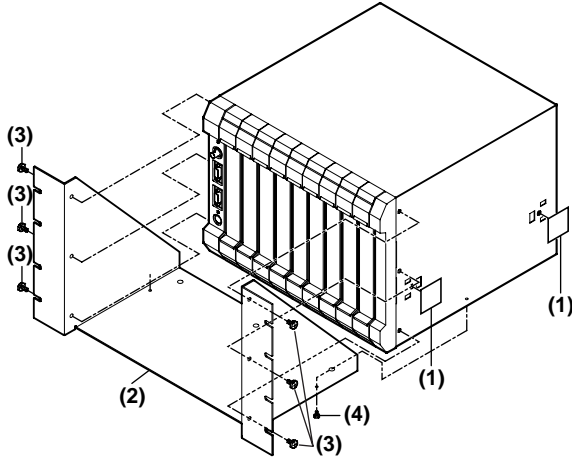

Model 7078636-J6 (JIS Standard)

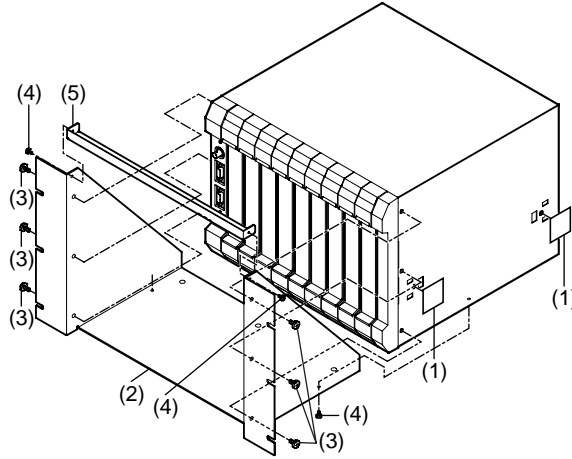

4. Procedure for mounting the station onto the rack

Mount the station according to the dimensions indicated below.

Note

1. Please have the station supported from the bottom. Make sure not to cover the ventilation holes in the process.
2. Allow 100 mm of space around the station for ventilation purposes.

Model 707863-E6 (ANSI/EIA Standard)

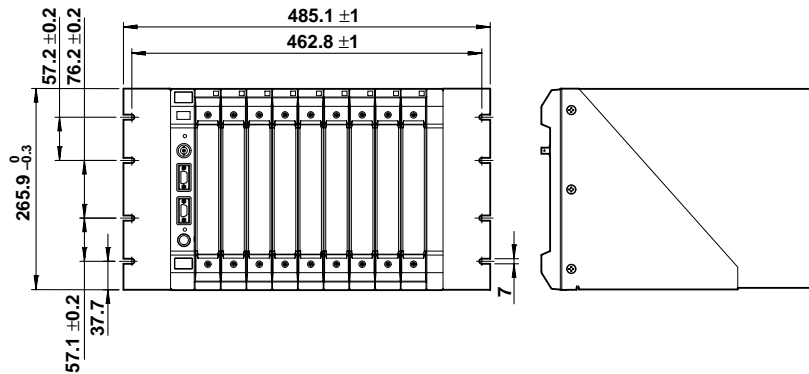

unit: mm

Model 7078636-J6 (JIS Standard)

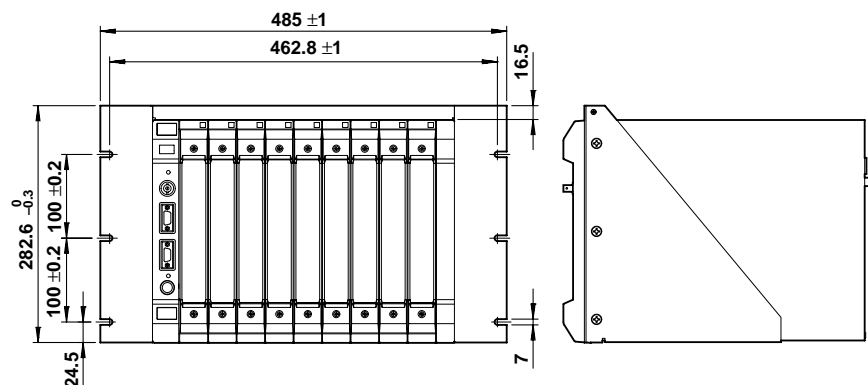

unit: mm